

Embedded TCP/IP 10-BaseT Network Module

Features

- 16-bit Microcontroller with Enhanced Flash program memory and static RAM data memory
- On board 10Mbps Ethernet controller, and RJ45 jack for network connection
- Small 2x3" circuit board footprint
- Single +3.3VDC supply
- Supports Microchip's TCP/IP protocol stack
- On board serial FLASH memory
- 80MHz CPU clock
- IEEE 802.3 10BaseT compliant
- Unique Ethernet Address
- Fully assembled and tested

Description

The eIP-24 is a small network module implemented with Microchip Technology PIC24HJ128GP202 16-bit High-Performance Microcontroller and ENC28J60 Ethernet Network Controller.

The circuit board includes all required components for both controllers, plus a serial 16Mbit FLASH for storage of board configuration, basic HTML pages and graphic files, three LEDs for health and board activity, and a RJ-45 jack with integrated magnetics and built-in Link and Activity LEDs for connection to an Ethernet Local Area Network.

Microcontroller SPI™ bus signals, ICSP™ interface, and many selectable I/O and peripheral pins are available on the board interface connectors.

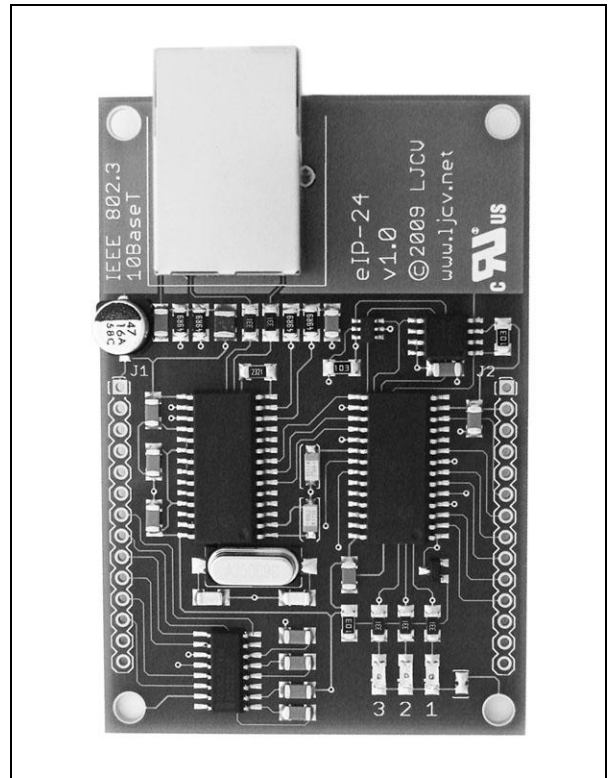

Applications

- Remote control and monitoring
- Data capture and logging
- Industrial Automation
- Building Automation
- Appliance remote management
- Robotics
- Microcontroller Research and Development
- TCP/IP Research and Development
- Serial Ethernet bridge

General Description

The eIP-24 board combines the flexibility and features of a small package PIC24HJ128GP202 16-bit microcontroller (MCU)^[B1] from Microchip Technology with their ENC28J60^[B2] IEEE 802.3 Stand-Alone Ethernet controller with integrated SPI bus interface, MAC and 10BASE-T PHY (ENC).

The board includes all support components for both controllers plus a 16Mbit serial FLASH for application and user data storage, and a 25AA02E48 serial EEPROM pre-programmed with a unique 48-bit Ethernet Address.

Communication between both controllers is implemented using the standard SPI (Serial Peripheral Interface) signals SCK (clock), SDI (serial data input) and SDO (serial data output). Given that the PIC24HJ128GP202 supports PPS (Peripheral Pin Select), the RP9 pin is configured by software to connect to the SDI signal of the SPI1 interface, RP8 to SPI1 SDO and RP6 to SPI1 SCK.

The SPI bus is also shared with the serial FLASH and EEPROM, the RB15, RB14, and RB13 are used to drive (active low) the Chip Select of the Ethernet Controller, the serial FLASH and the 25AA02E48 serial EEPROM respectively.

Clock source for the Microcontroller is derived from the CLKOUT pin of the Ethernet controller that includes its own oscillator circuit driven by a 25.00MHz parallel cut crystal. It's important that the firmware does not disable the CLKOUT output (by default 6.25MHz).

To achieve higher performance and recommended clock speeds for the SPI bus the Microcontroller is normally configured with PLL enabled and the CPU Clock registers set for an internal speed of 80MHz.

The MCU reset logic is implemented with a 10K resistor and a high speed switching diode, the MCU reset or MCLR signal is also present on the J2 board interface connector to complete the MCU ICSP™ (In Circuit Serial Programming) interface.

The board requires a stable +3.3VDC supply with at least 250mA (this requirement varies according to the use of available I/O ports).

Complete schematics of the eIP-24 are included in Appendix A.

Complete source code for the TCP/IP stack is available from Microchip for download.

Microcontroller

The PIC24HJ128GP202 is a high performance 16-bit Harvard architecture microcontroller with a reduced instruction set, that includes in the chip 128 Kbytes of enhanced Flash memory, 8,192 bytes of static RAM, 21 general purpose bidirectional I/O lines with Peripheral Pin Select (PPS) support, of which up to 10 can be configured as channels for the 10/12-bit A/D converter, two analog comparators, two SPI™ interfaces, two UART modules, one I²C module and more.

For a detailed feature description and complete documentation of the Microcontroller, please refer to Microchip's PIC24HJ128GP202 Data Sheet^[B1] and the PIC24H Family Reference Manual^[B6].

Ethernet Controller

Microchip's ENC28J60 is an IEEE 802.3 Stand Alone Ethernet controller with integrated MAC and 10BASE-T PHY modules. It has a 8 KBytes dual port static RAM buffer with hardware assisted circular receive FIFO and CRC generation.

It supports Unicast, Multicast and Broadcast packets, and programmable receive packet filtering.

The hardware CRC calculation module facilitates the in-buffer checksum generation for various network protocols.

It also includes two programmable LED outputs for LINK, Rx/Tx activity and collision status. These two outputs drive the LEDs present in the eIP-24 RJ-45 jack. By default the yellow LED indicates LINK status and the green LED Rx/Tx activity.

For a detailed feature description and complete documentation of the Ethernet Controller, please refer to Microchip's ENC28J60 Data Sheet^[B2].

Serial FLASH

The serial FLASH included in the eIP-24 board is a 16 Megabit SST25VF016B.

This external 2 MBytes memory facilitates the non-volatile storage of configuration information, user data, HTML pages and graphics, etc.

The FLASH endurance is 10,000 cycles with more than 100 years of data retention.

For a detailed feature description and complete documentation of the Serial FLASH, please refer to SST25VF016B Data Sheet^[B3].

Serial 25AA02E48 EEPROM

To use a unique and registered 48-bit Ethernet address, the board includes a serial 25AA02E48 EEPROM that is pre-programmed by Microchip with Globally Unique 48-bit Node address compatible with EUI-48TM and EUI-64TM.

The memory is organized as an array of 256 bytes with the upper 1/4 of the array write protected, on the last six bytes of this area is where the pre-programmed 48-bit Node is stored. The remaining part of the array (1,536 bits) are available for application use.

The firmware version included with the eIP-24 obtains the MAC address from this memory, the rest of the memory is not used but the standard serial EEPROM routines can be modified to take advantage of the remaining space to store application configuration or other user data.

For complete documentation please refer to Microchip's 25AA02E48 Data Sheet^[B4].

UART Interface

The PIC24HJ128GP202 includes two Universal Asynchronous Receiver Transmitter (UART) modules. Signals of each UART module can be configured via PPS to different I/O pins.

The firmware must configure the RP10 pin as the UART1 transmit data signal (TX) and RP11 as the receive data signal (RX).

These two signals are present on the J1 Board Interface Connector but are also routed via two solder jumpers (shorted by default) in the bottom side of the printed circuit board, through a quad RS-232 transceiver to bring the serial interface signals to a level compatible with EIA RS-232 and also available on the J1 connector.

Only one driver and one receiver of the RS-232 transceiver Integrated Circuit are used, but the remaining driver and receiver inputs and outputs are available via the J1 Board Interface connector. Properly wired and the MCU configured, these can be used to implement hardware flow control or to enable the second UART module.

LEDs

The eIP-24 board includes three status LEDs (marked 1, 2 and 3) for indication of MCU program status and activity. The LEDs are connected to RA3, RB4, and RB5 I/O pins of the MCU.

These three I/O pins are also present on the J2 connector for other use, if for any reason you want to completely disable the LED for a particular I/O pin you can remove the limiting resistor above of the particular LED or if you don't want to use the LEDs and avoid drawing current from the I/O pins you can remove the solder jumper to the right of the LEDs.

Board Interface (J1 & J2)

Connections to the board are performed via two 14 single row pads spaced .1" each.

	J1	J2	
+3V3	1	1	MCLR
RB7/INT0	2	2	+3V3
RB12	3	3	GND
SCK	4	4	RB0/PGD1
SDO	5	5	RB1/PGC1
SDI	6	6	RA4
R2IN	7	7	CLKOUT
T2OUT	8	8	RB3
R2OUT	9	9	RB2
T2IN	10	10	RA1
RS1_RX	11	11	RA0
RS1_TX	12	12	RA3
UART1_TX	13	13	RB4
UART1_RX	14	14	RB5

Physical Dimensions

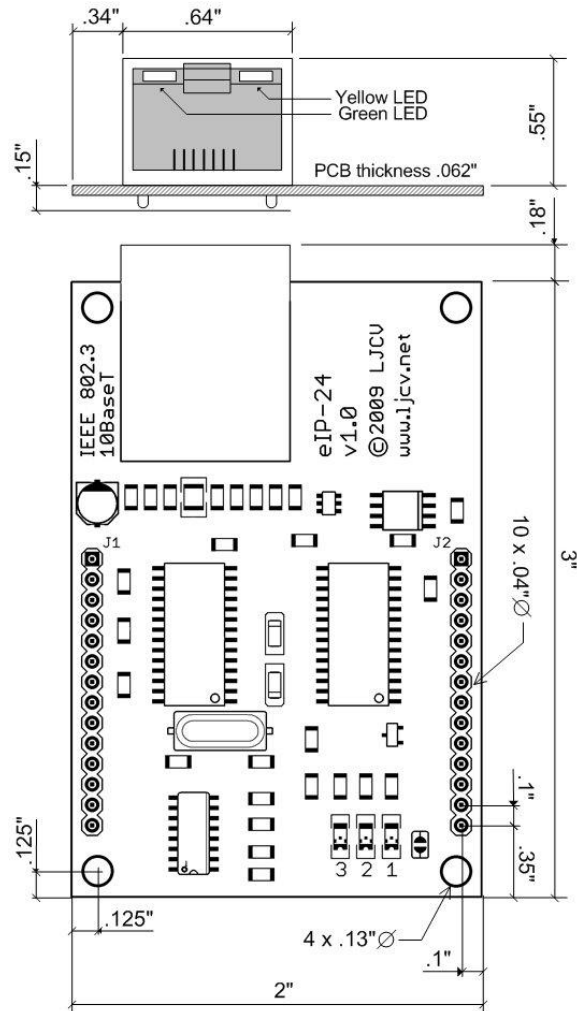

Note: Drawing not to scale

All dimensions are in inches.

Connecting the eIP-24

The eIP-24 is shipped fully assembled and tested. The Microcontroller program memory must be programmed with an appropriately configured and built image version of Microchip's TCP/IP stack.

The only connections required to get the board up and running are $V_{dd} = 3.3V$, GND and a 10BASE-T cable to your local area network or PC (be aware that if you connect the 10BASE-T cable directly to a PC Network Interface Card a crossover cable is needed).

The schematic below shows a basic circuit with the eIP-24 that includes the two pushbutton switches for BUTTON0 and BUTTON1 connected to RB2 and RB3, another pushbutton to force a hardware RESET of the Microcontroller connected to the MCLR pin, and a variable resistor connected to RA0 to produce an analog voltage level for the ADC module.

Programming the Microcontroller on the eIP-24 requires a programmer tool such as Microchip's In-Circuit Debugger/Programmer MPLAB® ICD3, PICKit-2, etc. The schematic also shows a RJ-11 6 position jack for the ICSP™ (In Circuit Serial Programming) to the Microcontroller that is configured to provide the programming interface via the RB0 and RB1 pins.

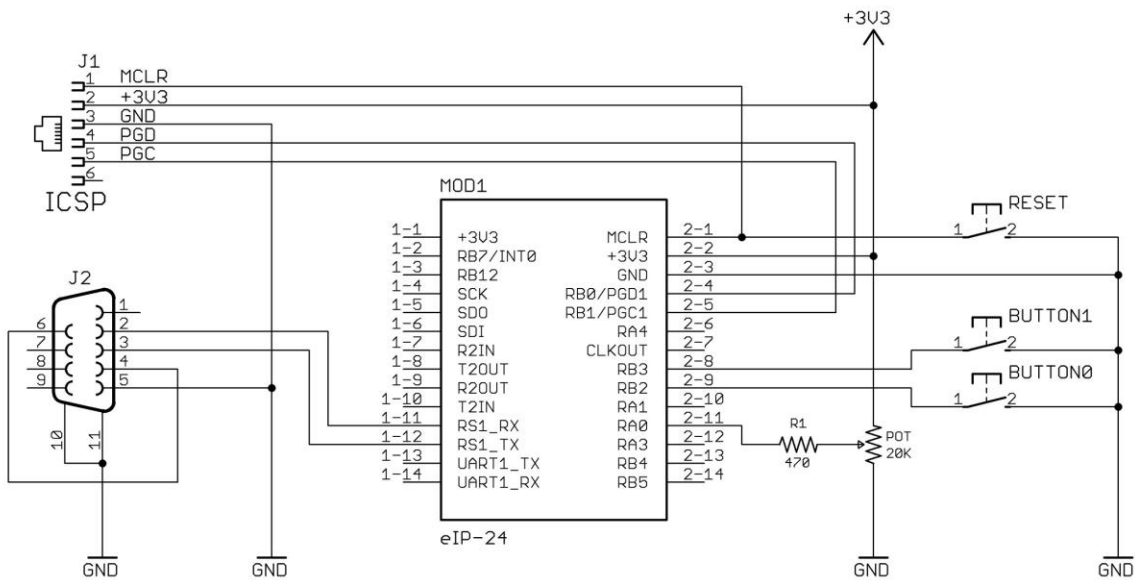

Taking advantage of the Microcontroller UART interface, the firmware uses this serial interface for configuration and debugging messages. The schematic also shows how to connect the eIP-24 board via a RS-232 serial interface such as a PC Serial Port using the RS-232 transceiver included in the board.

Electrical Characteristics

Absolute Maximum Ratings

Symbol	Parameter	Value	Unit
V_{dd}	Supply Voltage	-0.3 to +4.0	V
I_{SUP}	Supply Current (@ $V_{dd}=3.3V$)	250	mA
T_{OP}	Operating Temperature	-40 to +85	°C
T_{STO}	Storage Temperature	-65 to +150	°C

DC Normal Operating Characteristics

Symbol	Parameter	Value			Unit
		Min	Typ	Max	
V_{dd}	Supply Voltage	3.0	3.3	3.6	V
I_{SUP}	Supply Current (@ $V_{dd}=3.25V$)	200	210	230	mA
V_{IL}	Input Low Voltage (I/O ports)	V_{ss}	-	$0.2 V_{dd}$	V
V_{IH}	Input High Voltage (I/O ports)	$0.8 V_{dd}$	-	$V_{dd}^{(1)}$	V
V_{OL}	Output Low Voltage (I/O ports)	-	-	0.4	V
V_{OH}	Output High Voltage (I/O ports)	2.40	-	-	V

For complete AC and DC operating characteristics please refer to Microchip's PIC24HJ128GP202 Data Sheet^[B1].

- (1) Most of the digital I/O pins of the PIC24HJ128GP202 when configured as digital inputs are 5V tolerant, but not those who are shared with analog inputs. For detailed information about this feature consult the datasheet.

Appendix A – eIP-24 Schematics (1/2)

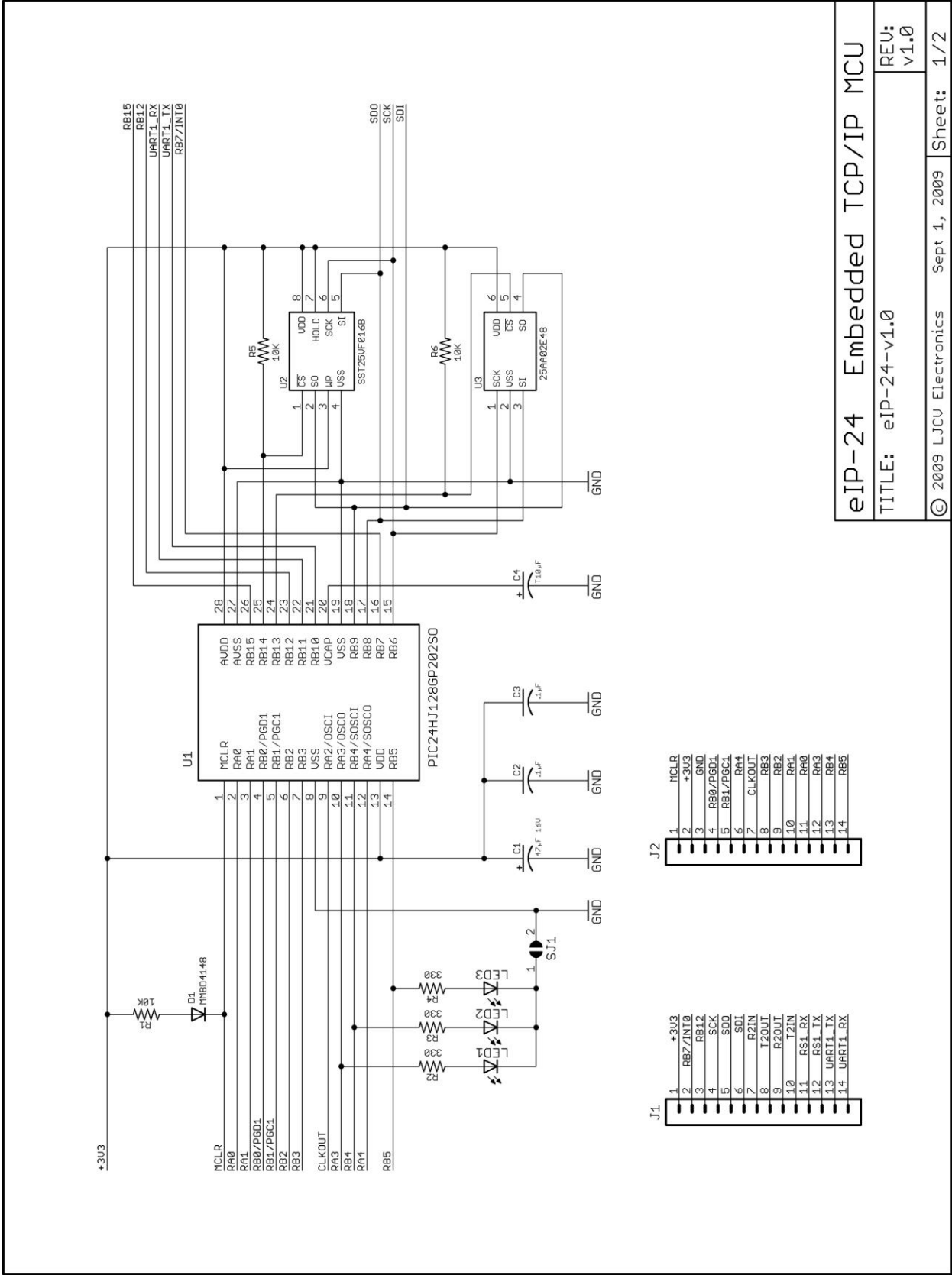

eIP-24 Embedded TCP/IP MCU	
TITLE: eIP-24-v1.0	REV: V1.0
© 2009 LJCVC Electronics Sept 1, 2009	Sheet: 1/2

Appendix A – eIP-24 Schematics (2/2)

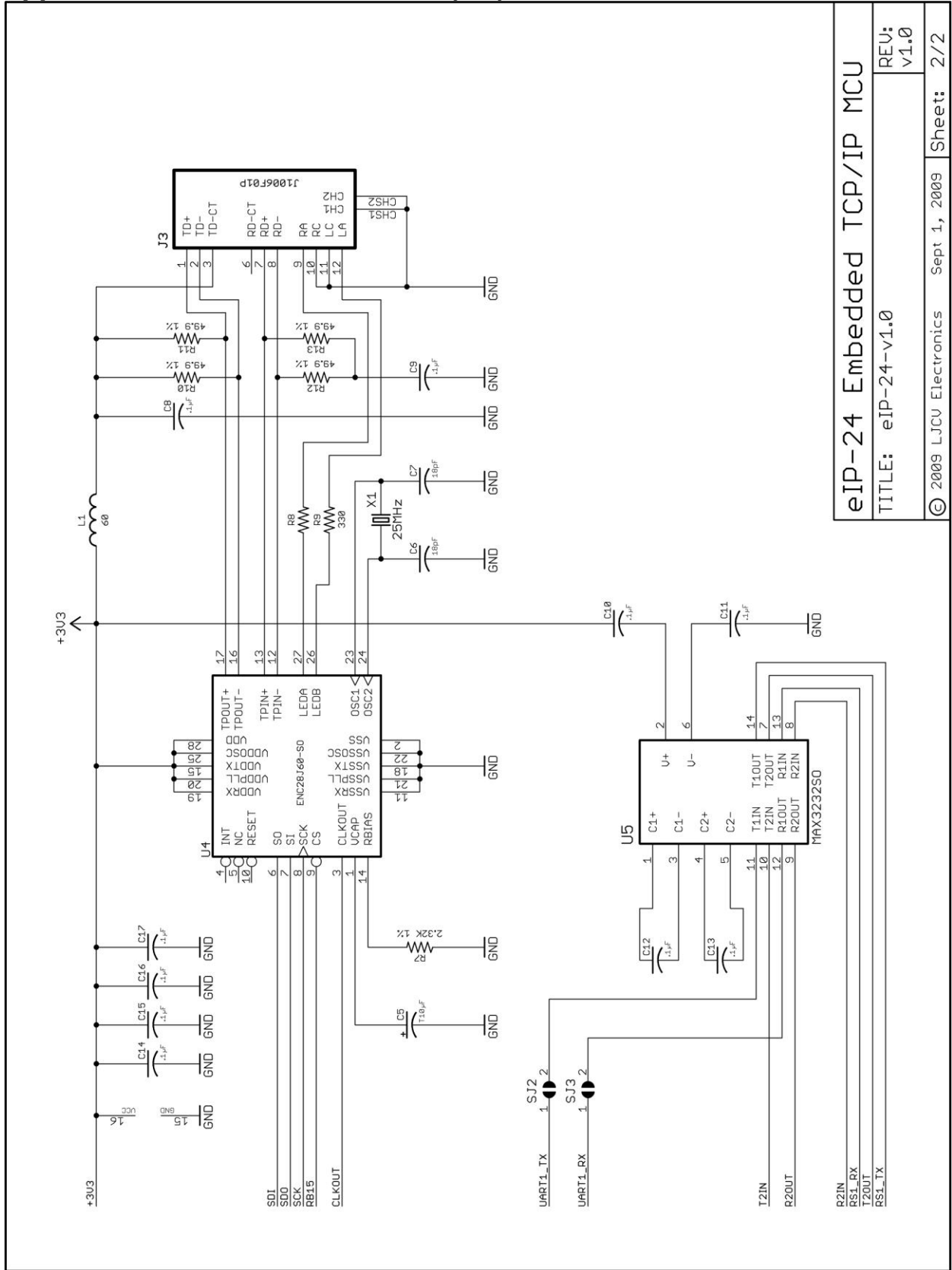

Appendix B – Technical References

- [B1] PIC24HJ128GP202 High-Performance 16-bit Microcontroller Data Sheet, Microchip Technology Inc., 2009, Document Number DS70293D.
- [B2] ENC28J60 Stand-Alone Ethernet Controller Data Sheet, Microchip Technology Inc., 2008, Document Number DS39662C.
- ENC28J60 Rev. B5 Silicon Errata, Microchip Technology Inc., 2006, Document Number DS80264C.
- ENC28J60 Rev. B7 Silicon Errata, Microchip Technology Inc., 2008, Document Number DS80349B.
- [B3] 16 Mbit SPI Serial Flash SST25VF016B, Silicon Storage Technology, Inc., 2008, Document Number S71271-03-000 9/08.
- [B4] 2K SPI Bus Serial EEPROM with EUJ-48™ Node Identity, Microchip Technology Inc., 2008, Document Number DS22123A.
- [B5] Microchip TCP/IP Protocol Stack v5.20, available at www.microchip.com/tcpip.
- [B6] PIC24H MCU Family Reference Manual, Microchip Technology Inc., 2009, Document Number DS70242B.

Revision History:

January 2010, Original data sheet document for eIP-24.
March 2010, Updated references to Microchip TCP/IP Stack.

Notes:

Information provided in this document is believed to be accurate and reliable. However LJCVC Electronics assumes no responsibility for errors or omissions. LJCVC Electronics assumes no responsibility for the use of this information or the devices and/or systems referenced in this document. This document may be subject of future updates and LJCVC reserves the right to discontinue production and change specifications and prices without notice. LJCVC Electronics makes no warranty of merchantability or fitness for any purposes.

© 2010, LJCVC Electronics, All Rights Reserved.
www.ljcv.net

SPI is a registered trademark of Motorola Corporation.

The Microchip name and logo, PIC, PICmicro, MPLAB, ICSP are registered trademarks of Microchip Technology Inc.

All other trademarks mentioned in this document are property of their respective companies.