

Note 1: R24 = 2.32k 1% for silicon Rev.B5, 2.7k 1% for Rev.B1/B4

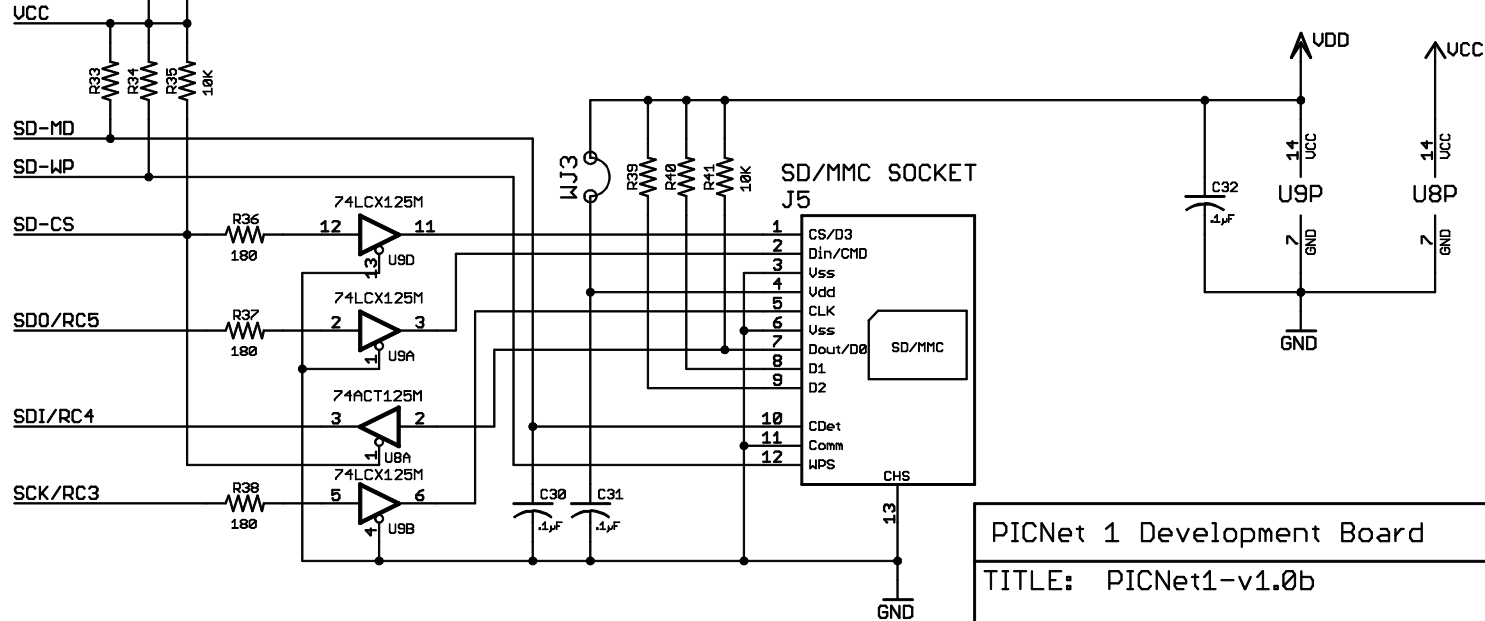

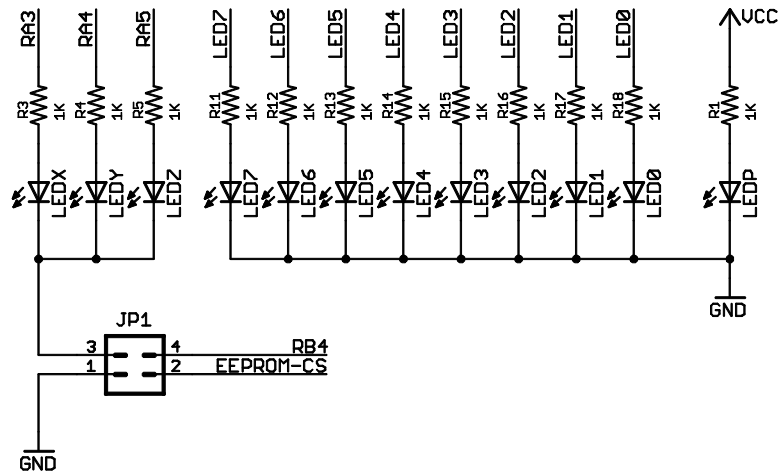
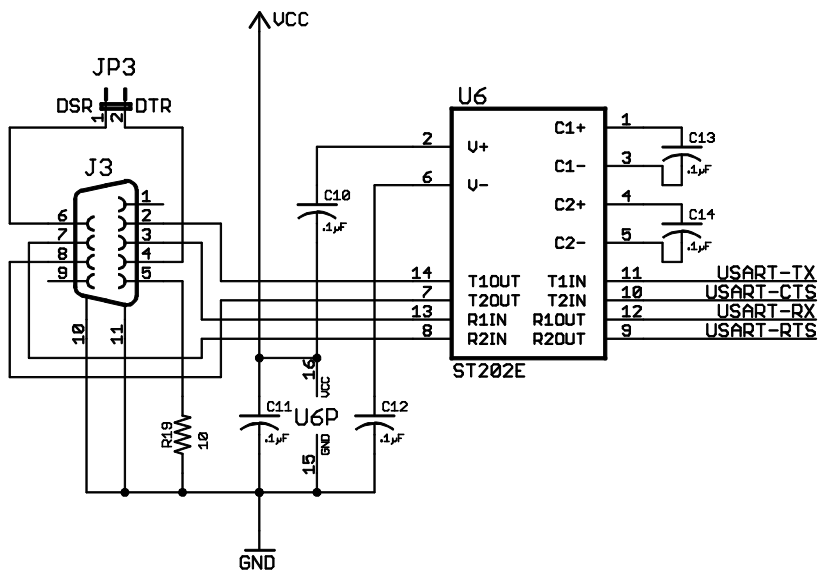
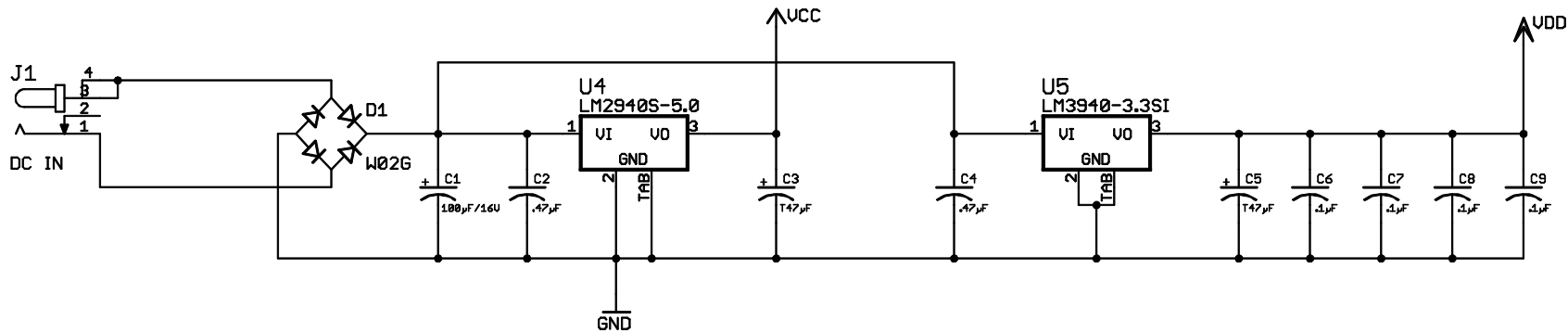

PICNet 1 Development Board	
TITLE: PICNet1-v1.0b	REV: 1.0b
©2006 -LJCU Electronics	Sheet: 3/4

Prototype area
GPIO access pads

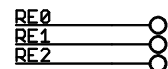
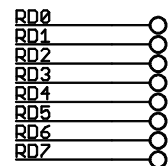
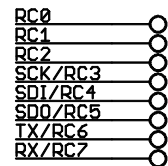
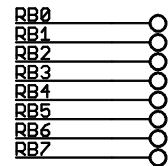
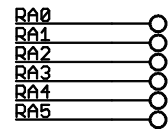

HW Options
interconnects

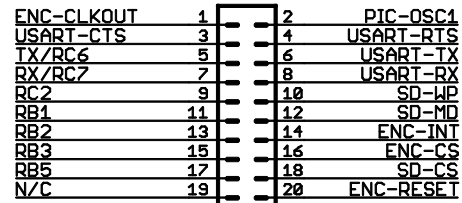

JP2

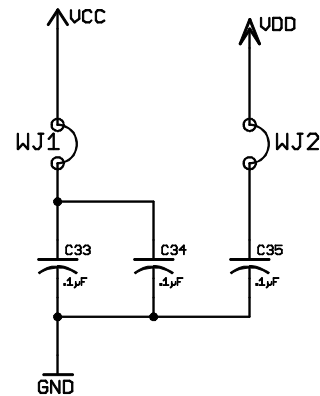

PICNet 1 Development Board

TITLE: PICNet1-v1.0b

REV:
1.0b

©2006 -LJCU Electronics

Sheet: 4/4